

# MOON

NEW WITH LED

3688L



MOONLED INDOOR & OUTDOOR SUCTION INSECT TRAP USES 6 UV-A LED WITH AN EMISSION OF 365 NM WHICH ARE ABLE TO ATTRACT FLYING INSECTS UP TO 6 METERS DISTANCE.

THE SPECIAL ACTINIC LED HAVE A HIGH ATTRACTIVE POWER TOGETHER WITH THE ADVANTAGE OF AN ENERGY CONSUMPTION OF 4 WATTS ONLY. THE FLYING INSECTS ARE SUCKED IN BY THE FAN AND ARE TRAPPED INTO A DRAWER, WHICH CLOSSES AUTOMATICALLY WHEN THE APPLIANCE IS TURNED OFF. THE DRAWER CAN EVENTUALLY BE EASILY REMOVED, EMPTIED AND WASHED.

THE UNIQUE AND ORIGINAL DESIGN IS COMBINED WITH A GREAT STURDINESS OF THE STRUCTURE AND WITH THE POSSIBILITY OF OUTDOORS SAFE POSITIONING (TERRACES, SWIMMING POOLS, GARDENS, ...) THANKS TO THE IP34 WATERPROOF CERTIFICATION.



MADE IN ITALY

## INDOOR & OUTDOOR

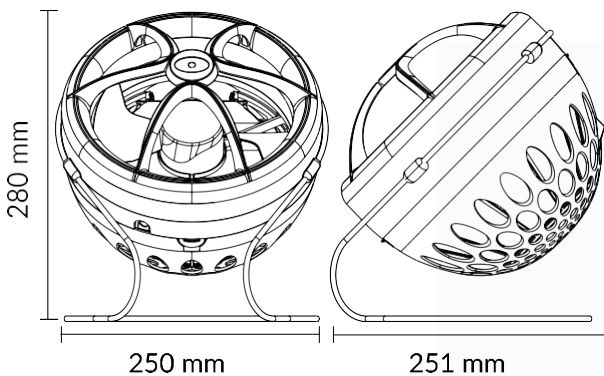

ONLY 6 LED UV-A  
RANGE OF ACTION: 7 LINEAR m  
LED MADE IN ITALY

# NEW



### TECHNICAL FEATURES

**3688B**

Dimensions	250 x 251 x 280 mm
Weight	1,27 kg
Power Supply	100-240V ~ 50-60 Hz
Power	9 W
Power Motore	4.5 W
Velocità motore	1200 rpm
Lamp	6 x 365nm LED
Lamp life	30.000h
Range of action	14/16 m
Bodywork	ABS
Insulating Class	II
EAN Code	8010114368820



IP34

14-16 m

